

3,2/√(✓)

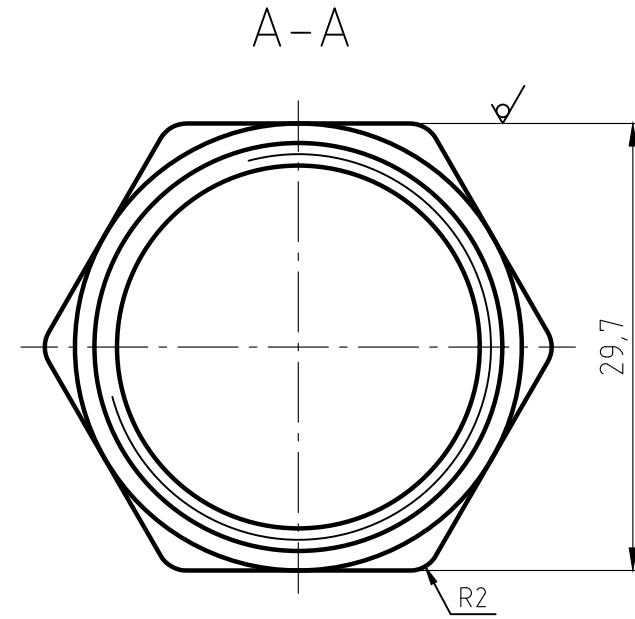
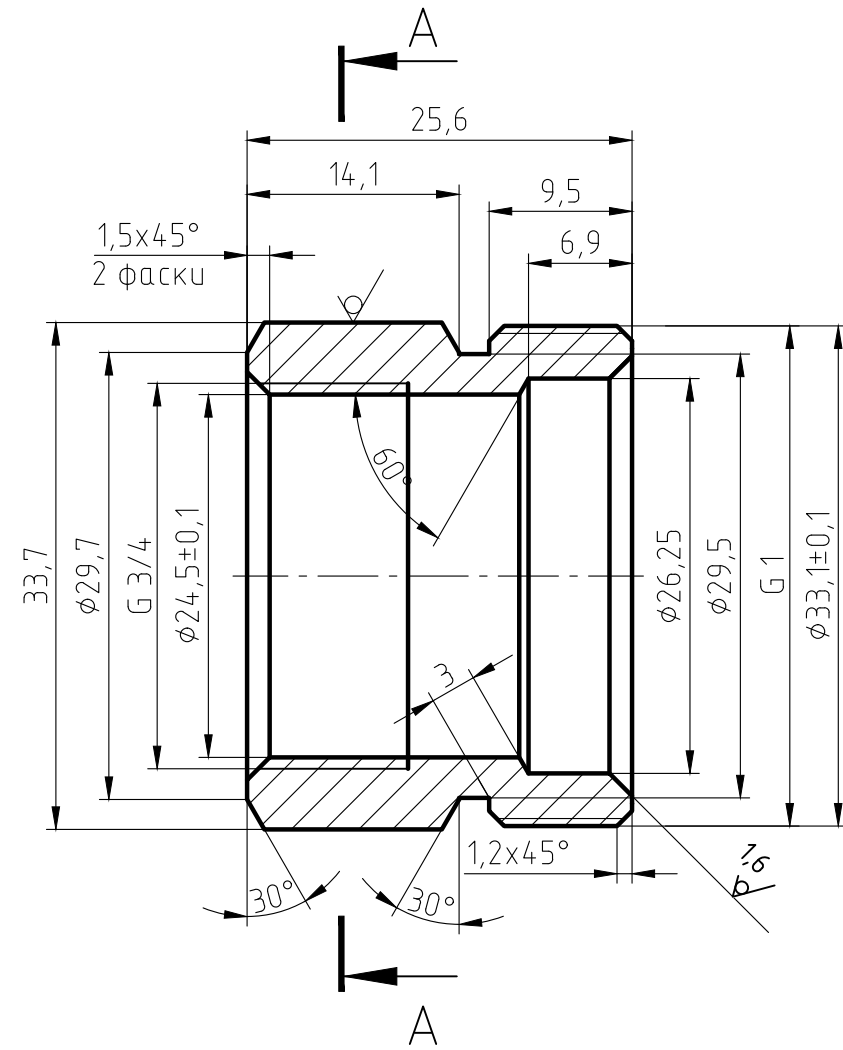

1. The parts should be 59-1 materials, no fissures surface sand-throwing treatment and nickel plating. All nickel plating.
2. Not specified R0.5, slope of 1\*.
3. The logo is cave/hollow, depth is 0,3-0,5 mm.
4. Surface is clear and smoothly, deburring C0.2.
5. The dimention on the drawings are of the finished products.
6. The Male thread should be bitten.

Перв. примен.	Справ. №	Подп. и дата	Инв. № дубл.	Взам. инв. №	Подп. и дата	Инв. № подл.
---------------	----------	--------------	--------------	--------------	--------------	--------------

					Гайка внутренняя прямой американки 3/4" вн ИС.072106-1	Лит.	Масса	Масштаб
Изм.	Лист	№ докум.	Подп.	Дата			51,9	2:1
Разраб.						Лист	Листов	1
Пров.								
Т.контр.								
Н.контр.					ЛС 59-1 ГОСТ 15527-2004			
Утв.								