

✓(✓)

Перв. примен.

Справ. №

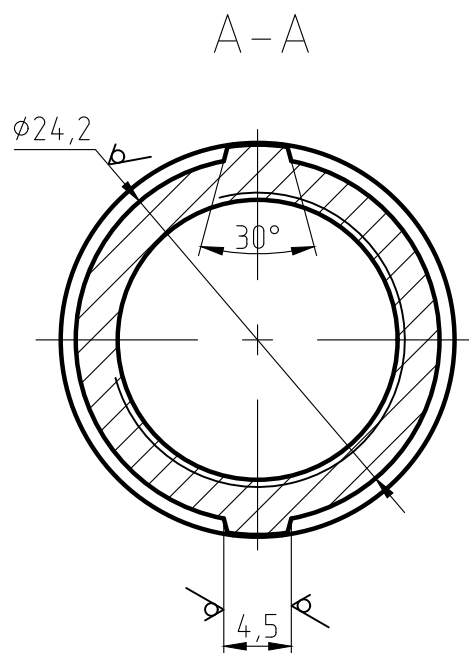
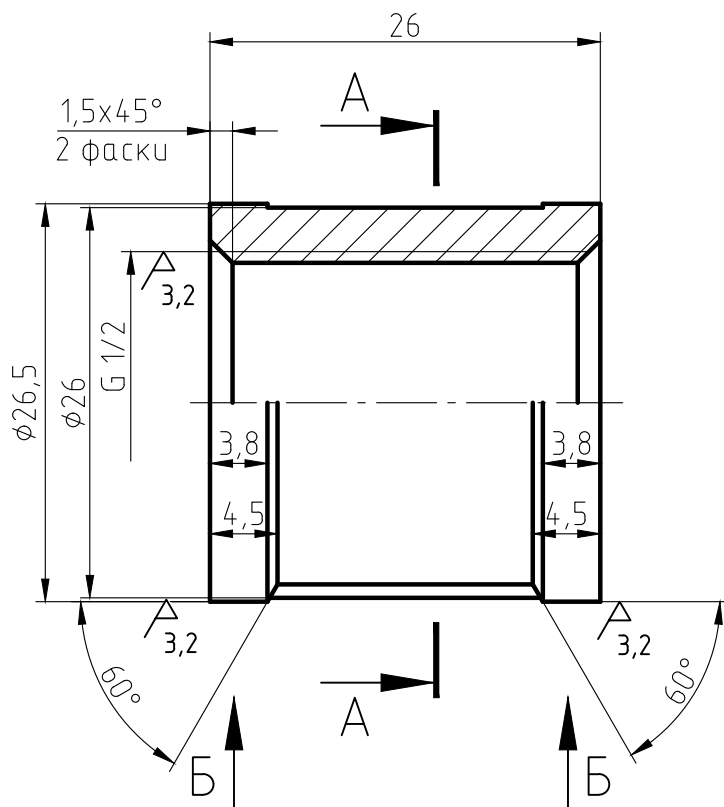

Б(1:1)

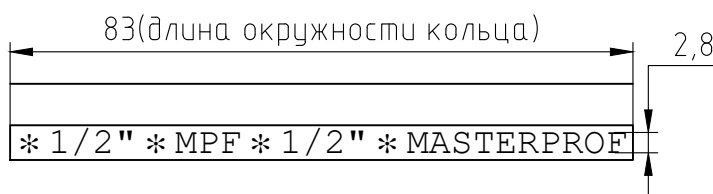

1. The parts should be 59-1 materials, no fissures surface sand-throwing treatment and nickel plating.
2. Not specified R0.5, slope of 1*.
3. The logo is cave/hollow. depth is 0.3-0.5 mm.
4. Surface is clear and smoothly, deburring C0.2.
5. The dimentions on the drawings are of the finished products.
6. The Male thread should be bitten.

Подп. и дата

Инв. № дубл.

Взам. инв. №

Подп. и дата

Инв. № подл.

Изм.	Лист	№ докум.	Подп.	Дата
Разраб.				
Пров.				
Т.контр.				
Н.контр.				
Утв.				

Муфта 1/2" ВВ
ИС.071984

Лит.	Масса	Масштаб
	40,6	2:1
Лист	Листов	1

ЛС 59-1 ГОСТ 15527-2004