

3,2/√(✓)

Перв. примен.

Справ. №

Подп. и дата

Инв. № дубл.

Взам. инв. №

Подп. и дата

Инв. № подл.

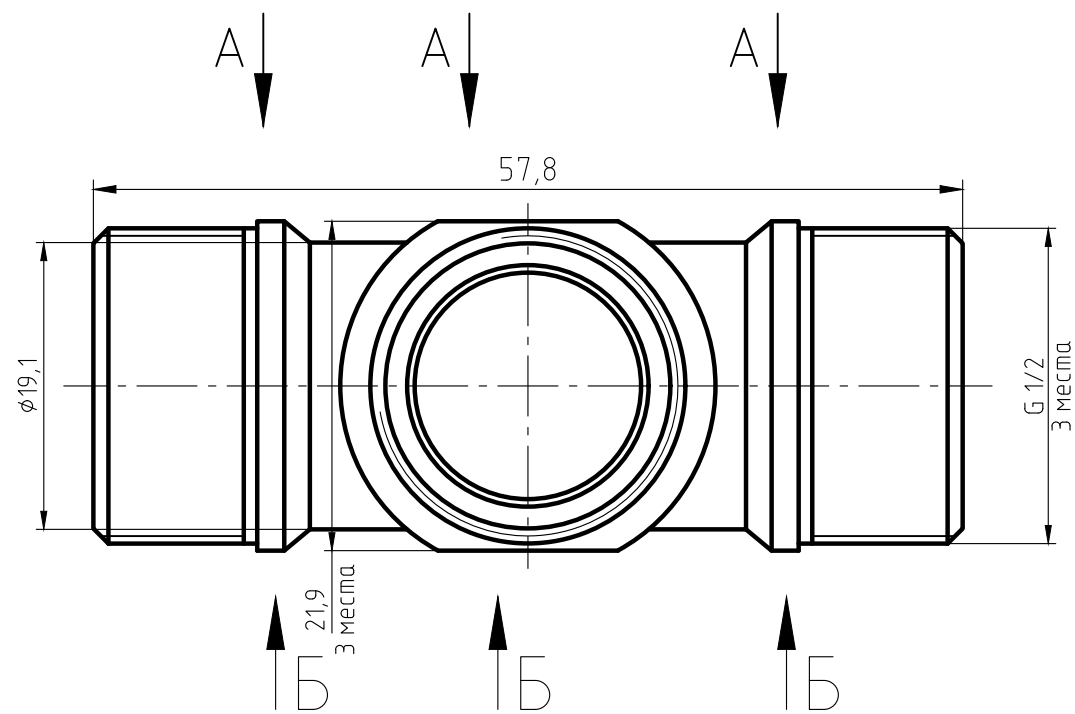
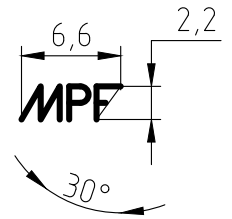
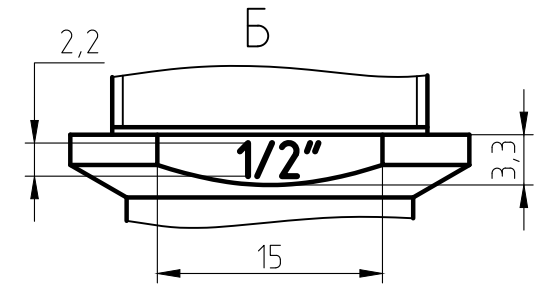
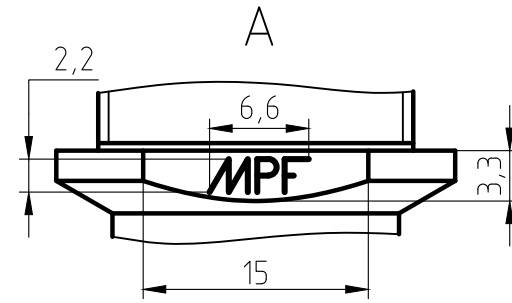
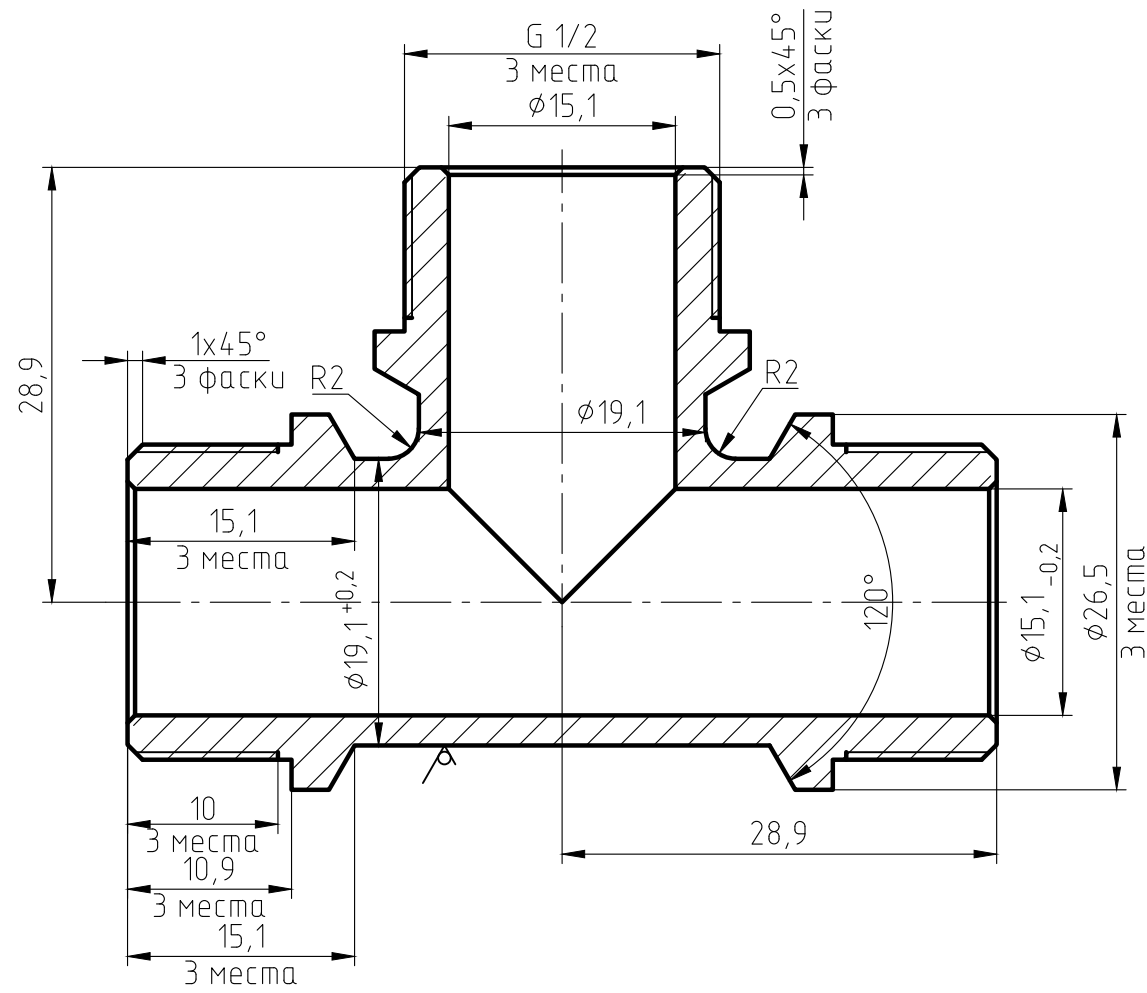

1. The parts should be 59-1 materials, no fissures surface sand-throwing treatment and nickel plating. All nickel plating.
2. Not specified R0,5, slope of 1*.
3. The logo is cave/hollow. depth is 0,3-0,5 mm.
4. Surface is clear and smoothly, deburring C0,2.
5. The dimintions on the drawings are of the finished products.
6. The Male thread should be bitten.

					Тройник 1/2" ННН ИС.072072		
Изм.	Лист	№ докум.	Подп.	Дата	Лит.	Масса	Масштаб
Разраб.						91	2:1
Пров.					Лист		Листов
Т.контр.					ЛС 59-1 ГОСТ 15527-2004		
Н.контр.							
Утв.							