

3.2

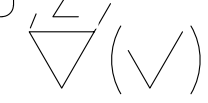
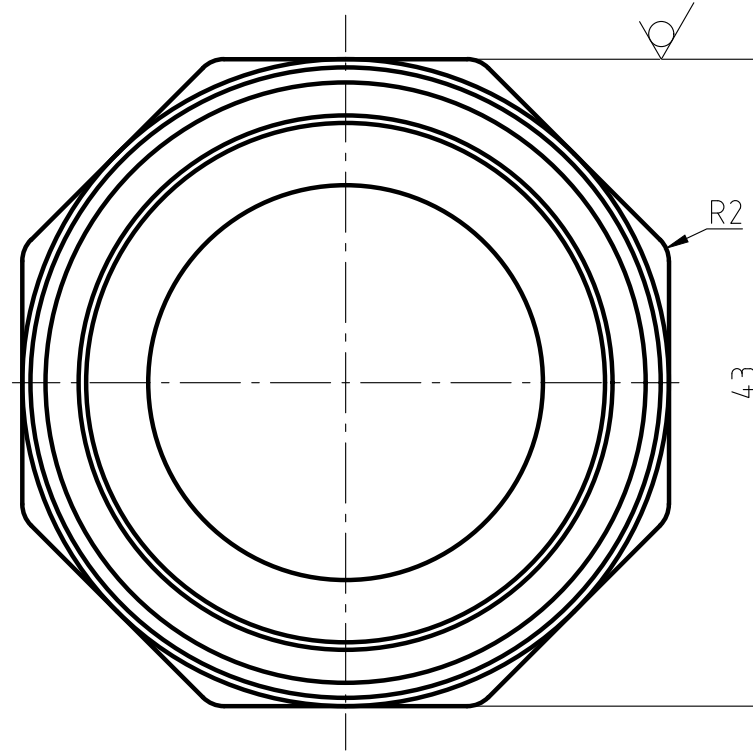
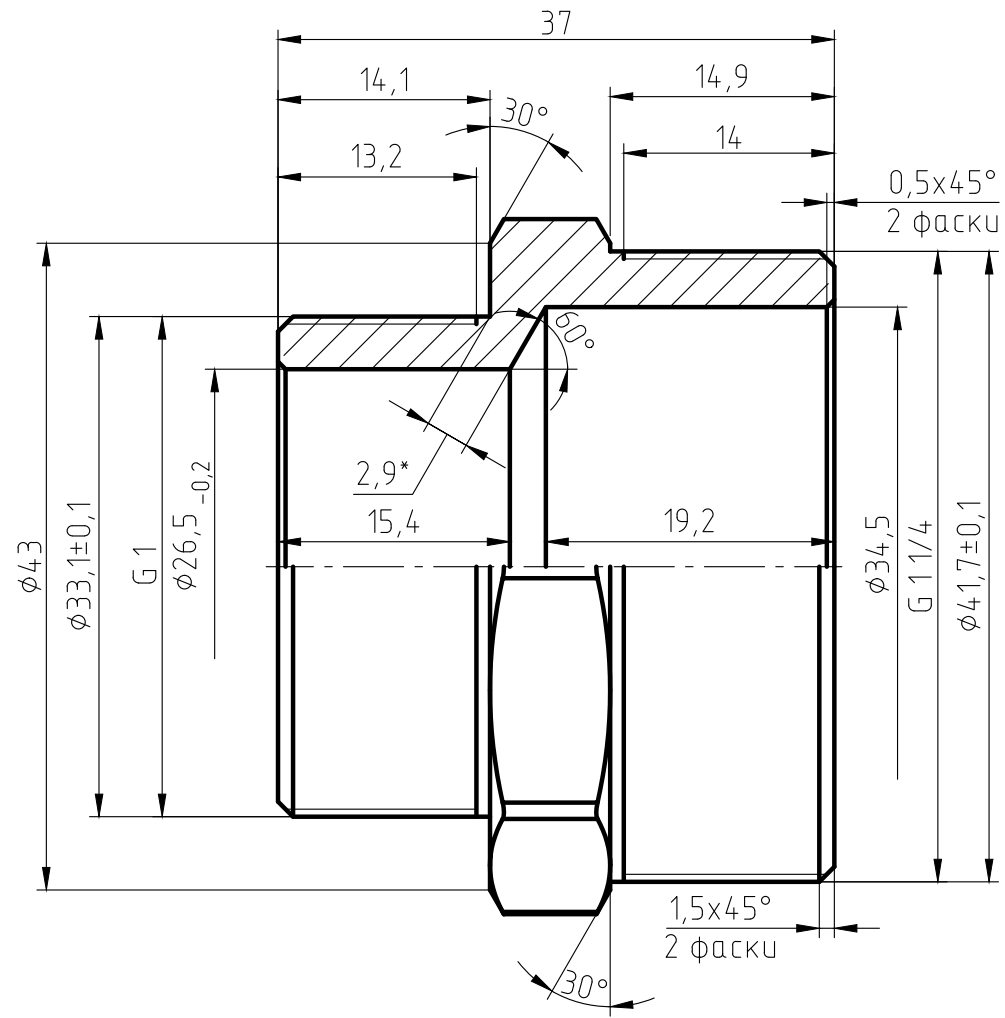

1. The parts should be 59-1 materials, no fissures surface sand-throwing treatment and nickel plating. All nickel plating.
2. Not specified R0.5, slope of 1*.
3. Surface is clear and smoothly, deburring C0.2.
4. The dimentions on the drawings are of the finished products.
5. The Male thread should be bitten.

Изм.	Лист	№ докум.	Подп.	Дата	Ниппель переходник 1"x1 1/4" НН ИС.072019			Лист	Масса	Масштаб
Разраб.								119,9	2:1	
Пров.										
Т.контр.								Листов	1	
Н.контр.					ЛС 59-1 ГОСТ 15527-2004					
Утв.										

Перв. примен.

Справ. №

Подп. и дата

Инд. № дудл.

Взам. инв. №

Подп. и дата

Инд. № подл.