

3.2 / (✓)

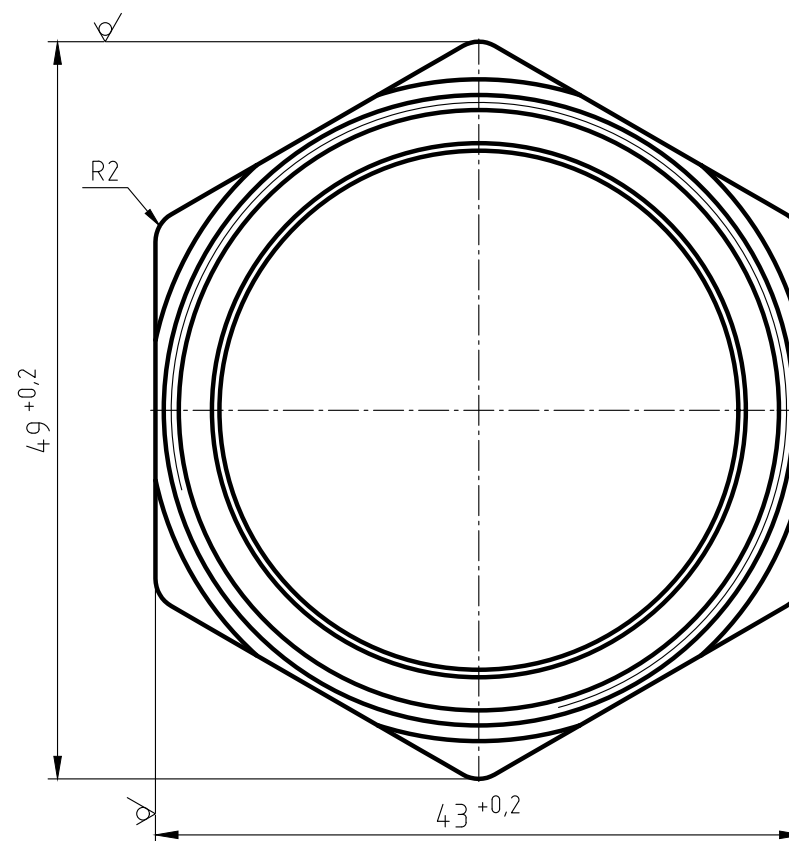
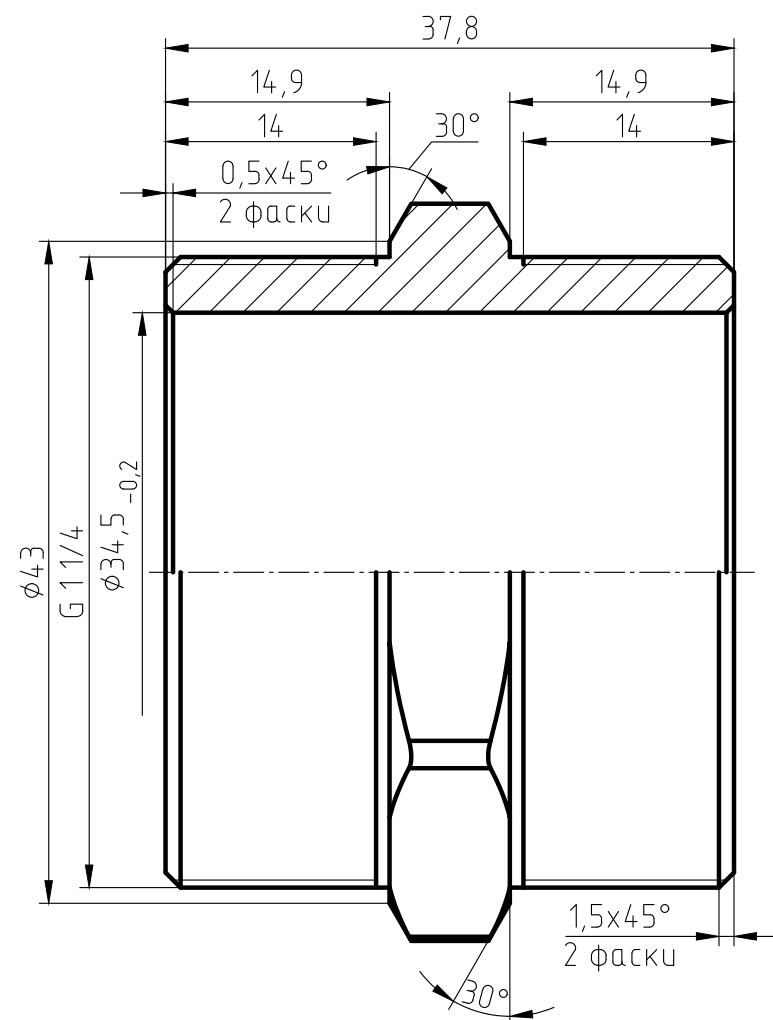

1. The parts should be 59-1 materials, no fissures surface sand-throwing treatment and nickel plating. All nickel plating.
2. Not specified R0.5, slope of 1\*.
3. Surface is clear and smoothly, deburring C0.2.
4. The dimentions on the drawings are of the finished products.
5. The Male thread should be bitten.

Перв. примен.	
Справ. №	
Подп. и дата	
Инв. № дудл.	
Взам. инв. №	
Подп. и дата	
Инв. № подл.	

Изм.	Лист	№ докум.	Подп.	Дата	<p>Ниппель 1 1/4" НН ИС.072008</p> <p>ЛС 59-1 ГОСТ 15527-2004</p>	Лист	Масса	Масштаб
Разраб.							130	2:1
Пров.						Лист	Листов	1
Т.контр.								
Н.контр.								
Утв.								