

3,2/√(✓)

Перв. примен.

Справ. №

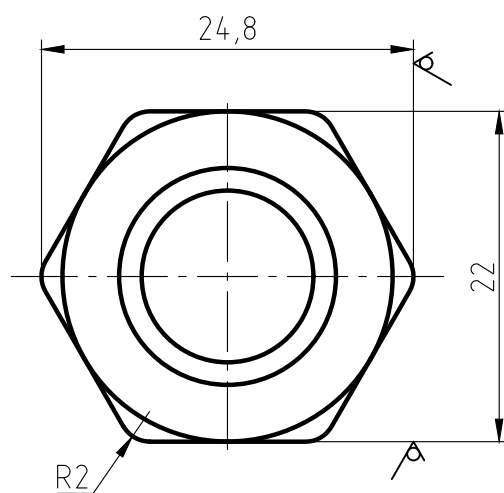
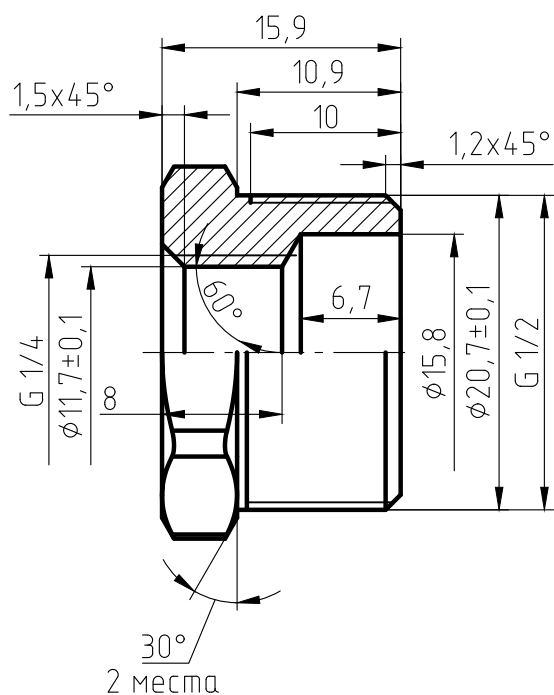

Подп. и дата

Инв. № дубл.

Взам. инв. №

Подп. и дата

Инв. № подл.

1. The parts should be 59-1 materials, no fissures surface sand-throwing treatment and nickel plating.
2. Not specified R0.5, slope of 1\*.
3. The logo is cave/hollow, depth is 0,3-0,5 mm.
4. Surface is clear and smoothly, deburring C0.2.
5. The dimentions on the drawings are of the finished products.
6. The Male thread should be bitten.

Изм.	Лист	№ докум.	Подп.	Дата
Разраб.				
Пров.				
Т.контр.				
Н.контр.				
Утв.				

Футорка 1/2"x1/4" нв  
ИС.072043

Лит.	Масса	Масштаб
	25,3	2:1
Лист	Листов	

ЛС 59-1 ГОСТ 15527-2004