

Перв. примен.

Справ. №

Подп. и дата

Инв. № дубл.

Взам. инв. №

Подп. и дата

Инв. № подл.

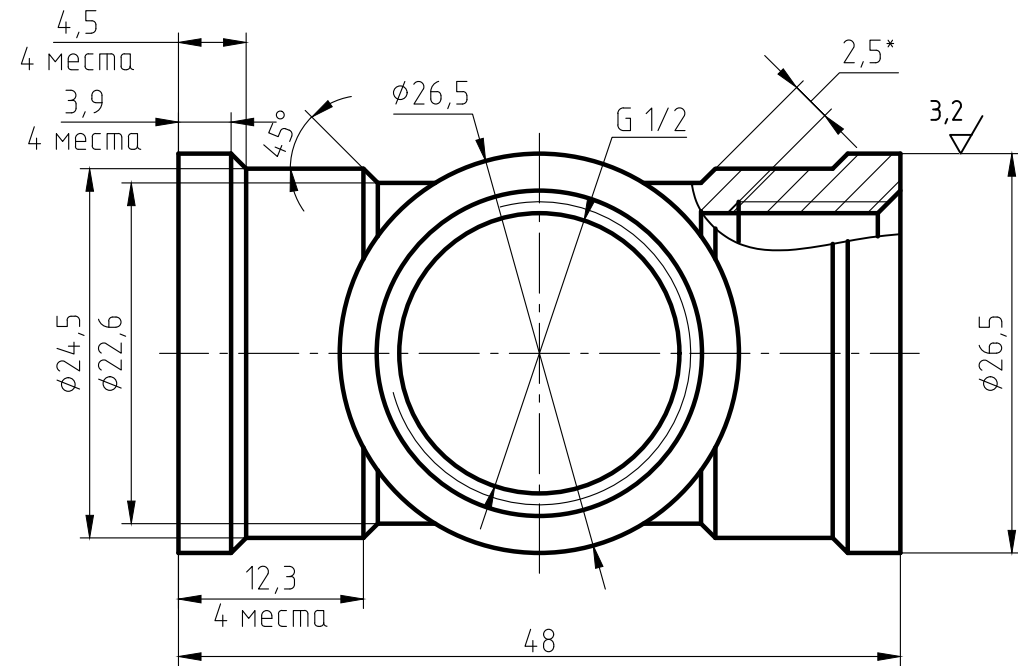
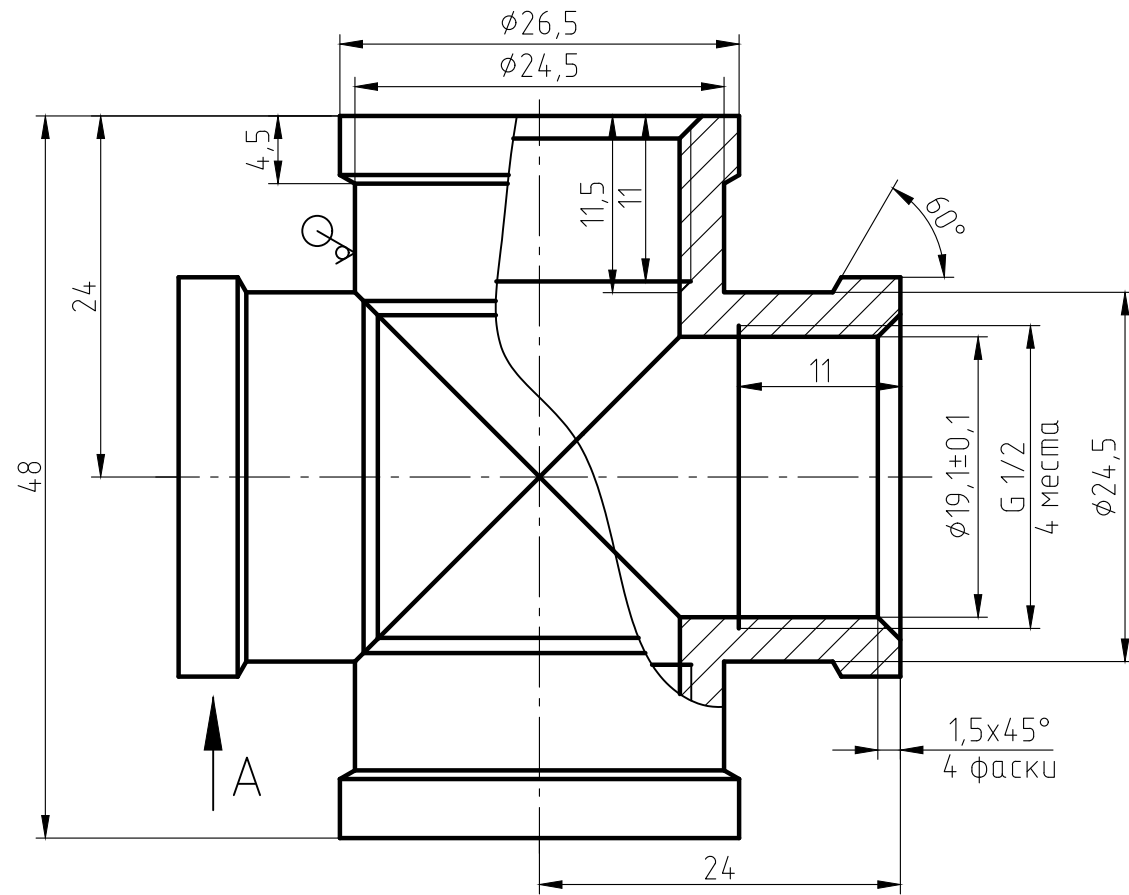

A(1:1)

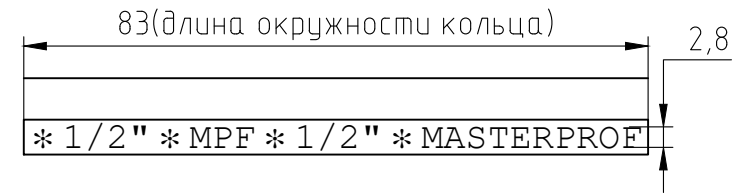

1. The parts should be 59-1 materials, no fissuress surface sand-throwing treatment and nickel plating. All nickel plating.
2. Not specified R0.5, slope of 1\*.
3. The logo is cave/hollow. depth is 0.3-0.5 mm.
4. Surface is clear and smoothly, deburring C0.2.
5. The dimintions on the drawings are of the finished products.
6. The Male thread should be bitten.

|          |      |          |       |      |                                   |      |        |         |
|----------|------|----------|-------|------|-----------------------------------|------|--------|---------|
| Изм.     | Лист | № докум. | Подп. | Дата | Крестовина 1/2" ВВВВ<br>ИС.072139 | Лит. | Масса  | Масштаб |
| Разраб.  |      |          |       |      |                                   |      | 102,5  | 2:1     |
| Пров.    |      |          |       |      |                                   | Лист | Листов |         |
| Т.контр. |      |          |       |      |                                   |      |        |         |
| Н.контр. |      |          |       |      | ЛС 59-1 ГОСТ 15527-2004           |      |        |         |
| Утв.     |      |          |       |      |                                   |      |        |         |